

University of Denver

Digital Commons @ DU

Fuel Efficiency Automobile Test Publications

Fuel Efficiency Automobile Test Data Repository

2003

A Five-Channel, Single Detector, Emission Remote Sensor (Presentation)

Mitchell J. Williams
University of Denver

Donald H. Stedman
University of Denver

Gary A. Bishop
University of Denver, gabishop10@yahoo.com

Richard W. Quine
University of Denver, rquine@du.edu

Follow this and additional works at: https://digitalcommons.du.edu/feat_publications

 Part of the [Environmental Chemistry Commons](#)

Recommended Citation

Williams, M. J.; Stedman, D. H.; Bishop, G. A.; Quine, R. J., A Five-Channel, Single Detector, Emission Remote Sensor, presented at the 13th Coordinating Research Council On-Road Vehicle Emissions Workshop: San Diego, 2003.

This Presentation is brought to you for free and open access by the Fuel Efficiency Automobile Test Data Repository at Digital Commons @ DU. It has been accepted for inclusion in Fuel Efficiency Automobile Test Publications by an authorized administrator of Digital Commons @ DU. For more information, please contact jennifer.cox@du.edu, dig-commons@du.edu.

A Five-Channel, Single Detector, Emission Remote Sensor (Presentation)

Publication Statement

Public Domain

Publication Statement

Public Domain

A Five-Channel, Single Detector, Emissions Remote Sensor.

Mitchell J. Williams, Donald H. Stedman, Gary A. Bishop, University of
Denver, Department of Chemistry & Biochemistry, Richard J. Quine Dept.
of Engineering, Denver, CO. 80208-2436.

www.feat.biochem.du.edu

303 871-2580.. FAX 2587
dstedman@du.edu



Schematic Diagram of the new University of Denver UV/IR Remote Sensor

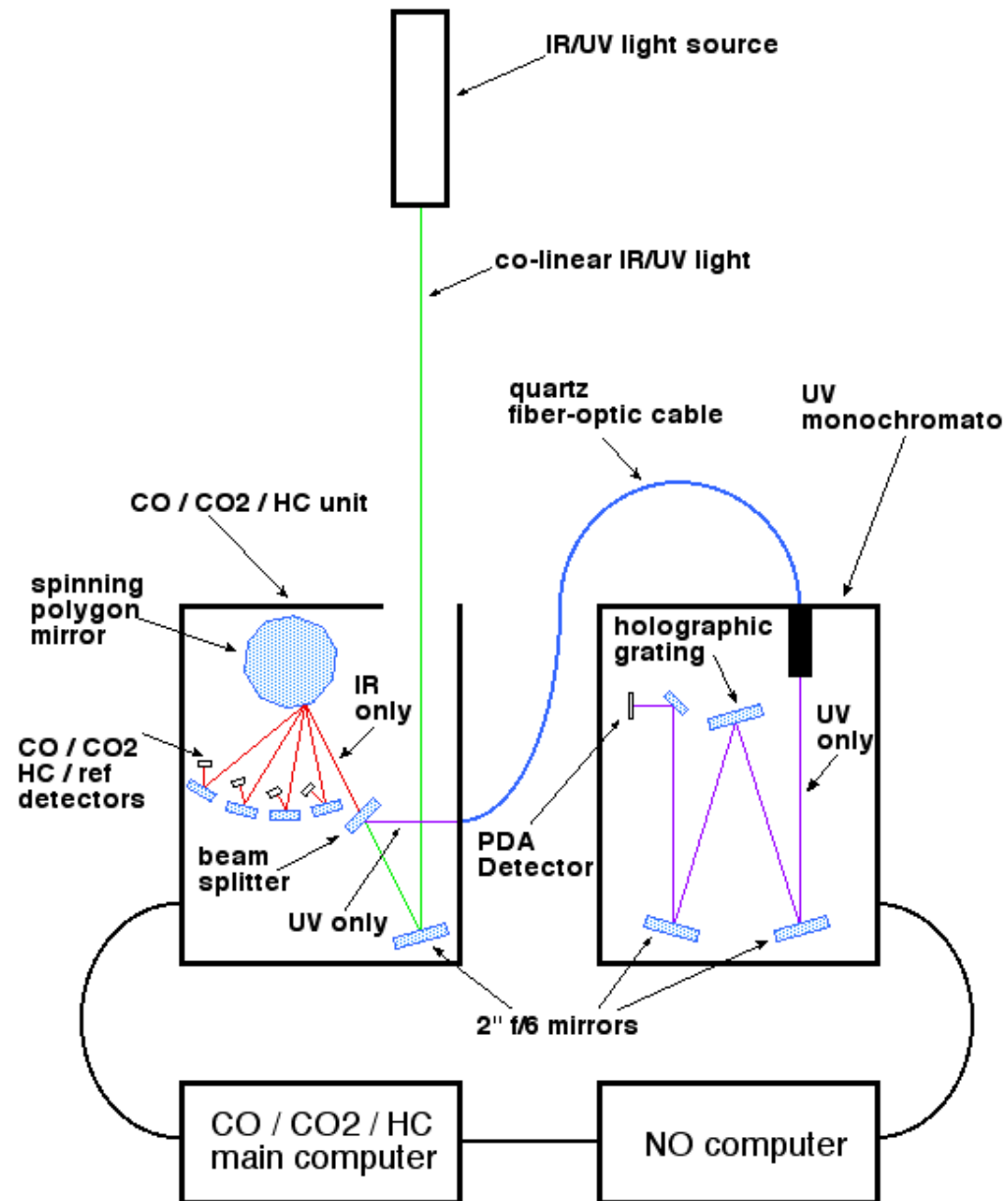

The New System Should:

Agree with the old

Self correct for CO₂ variation

Distinguish “Steamers” from high HC
Vehicles

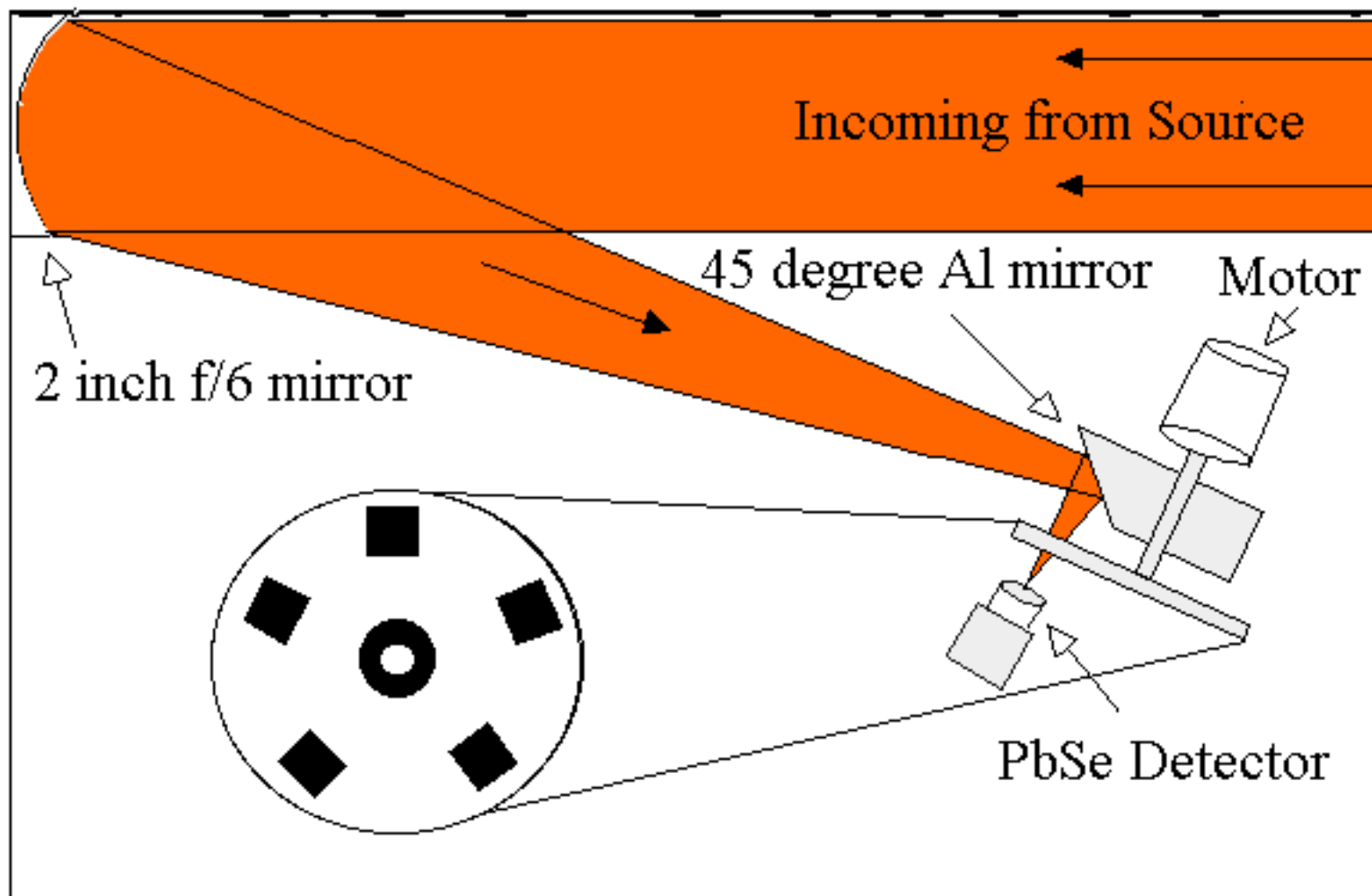

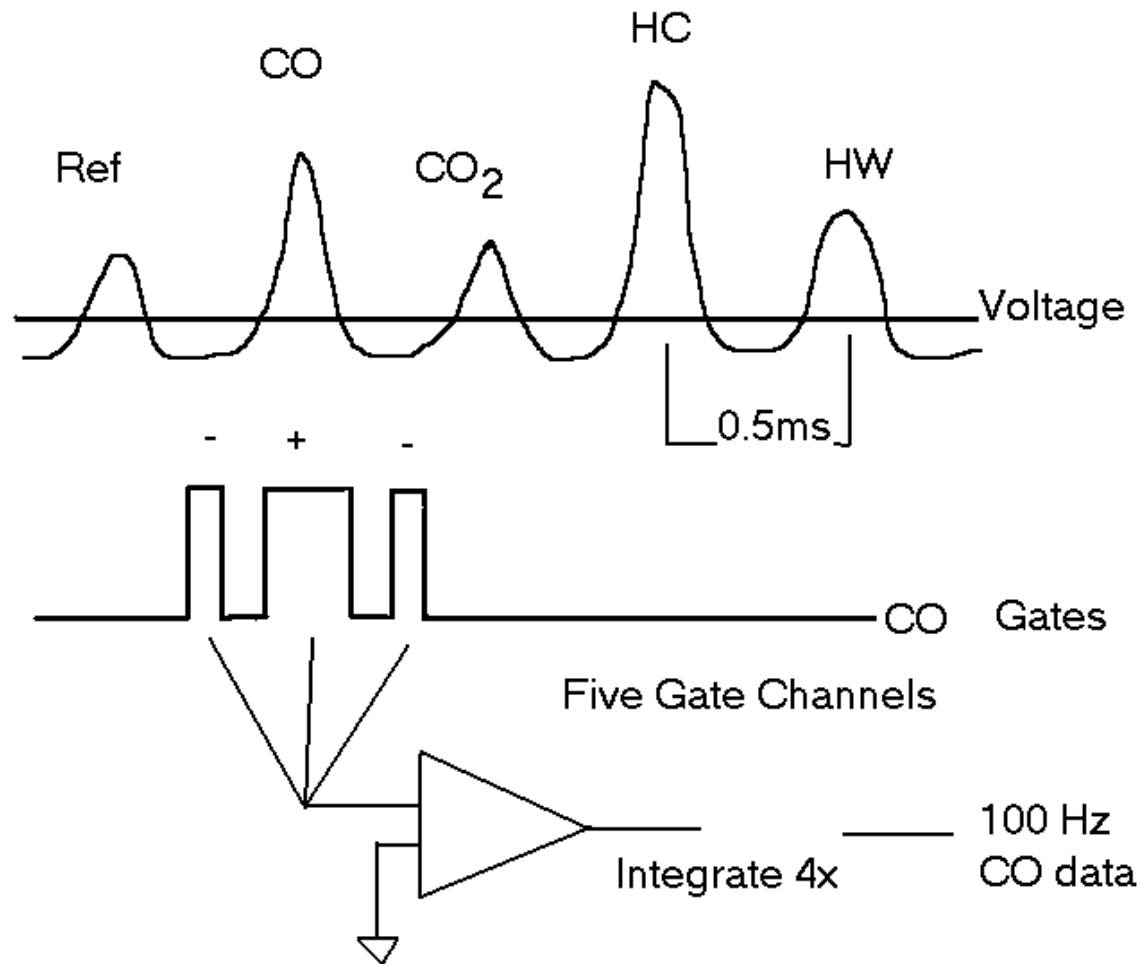

February 2003
SGM Parking Lot
CO Correlation
110 Measurements

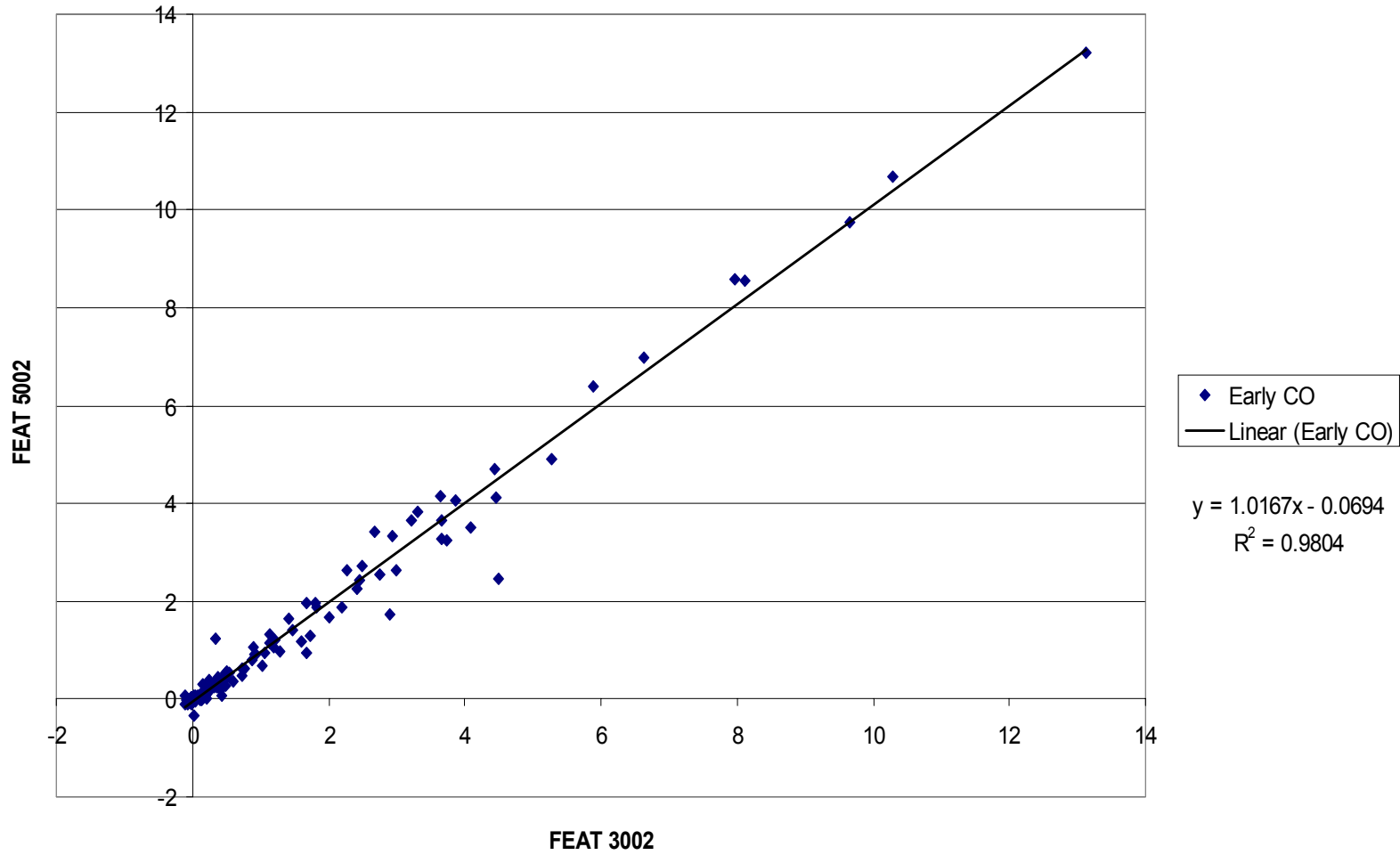

North I-25 onto West 6th Ave
January 2003
CO Correlation
7293 Measurements

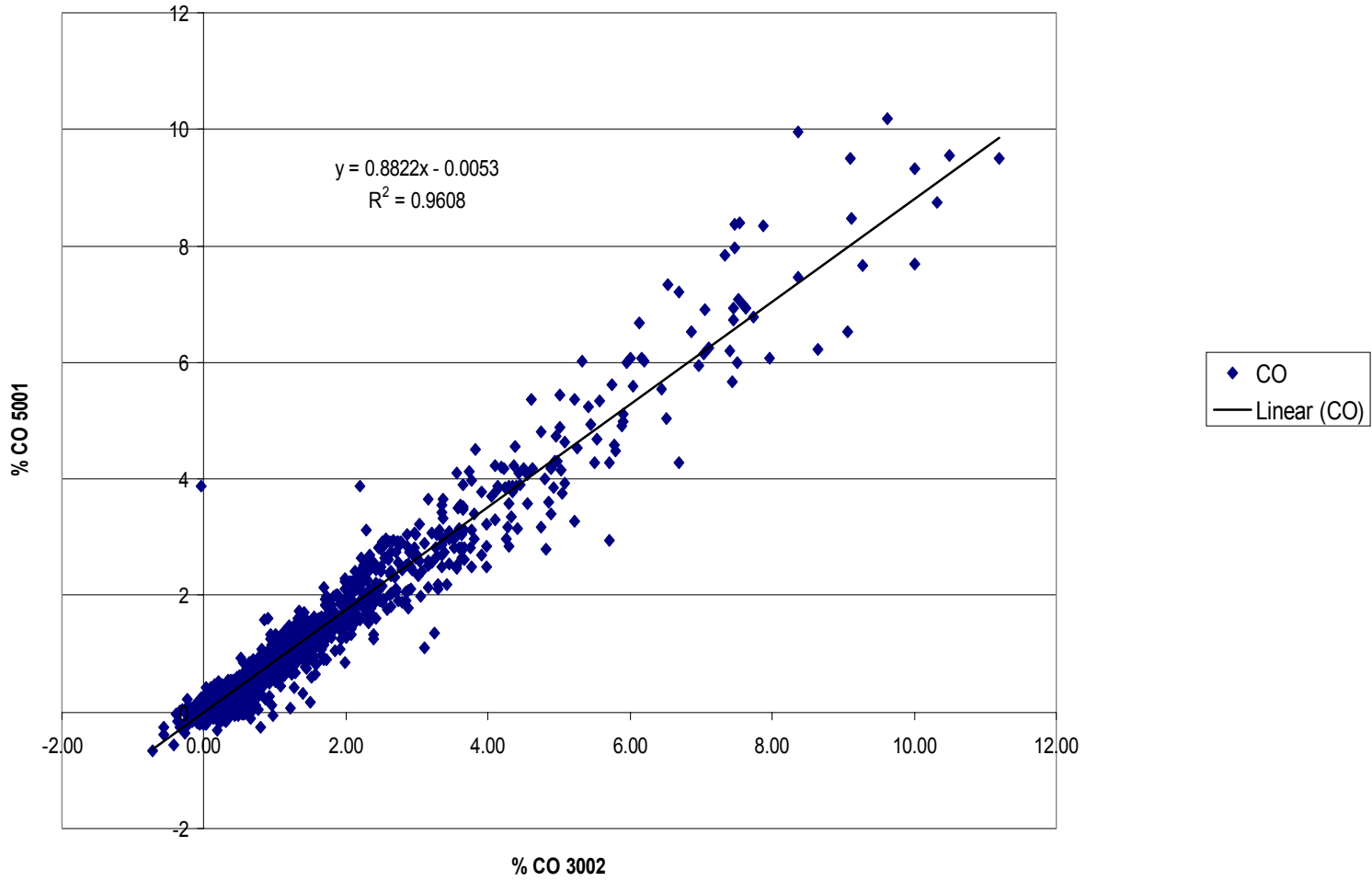

HC Correlation 7433 vehicles

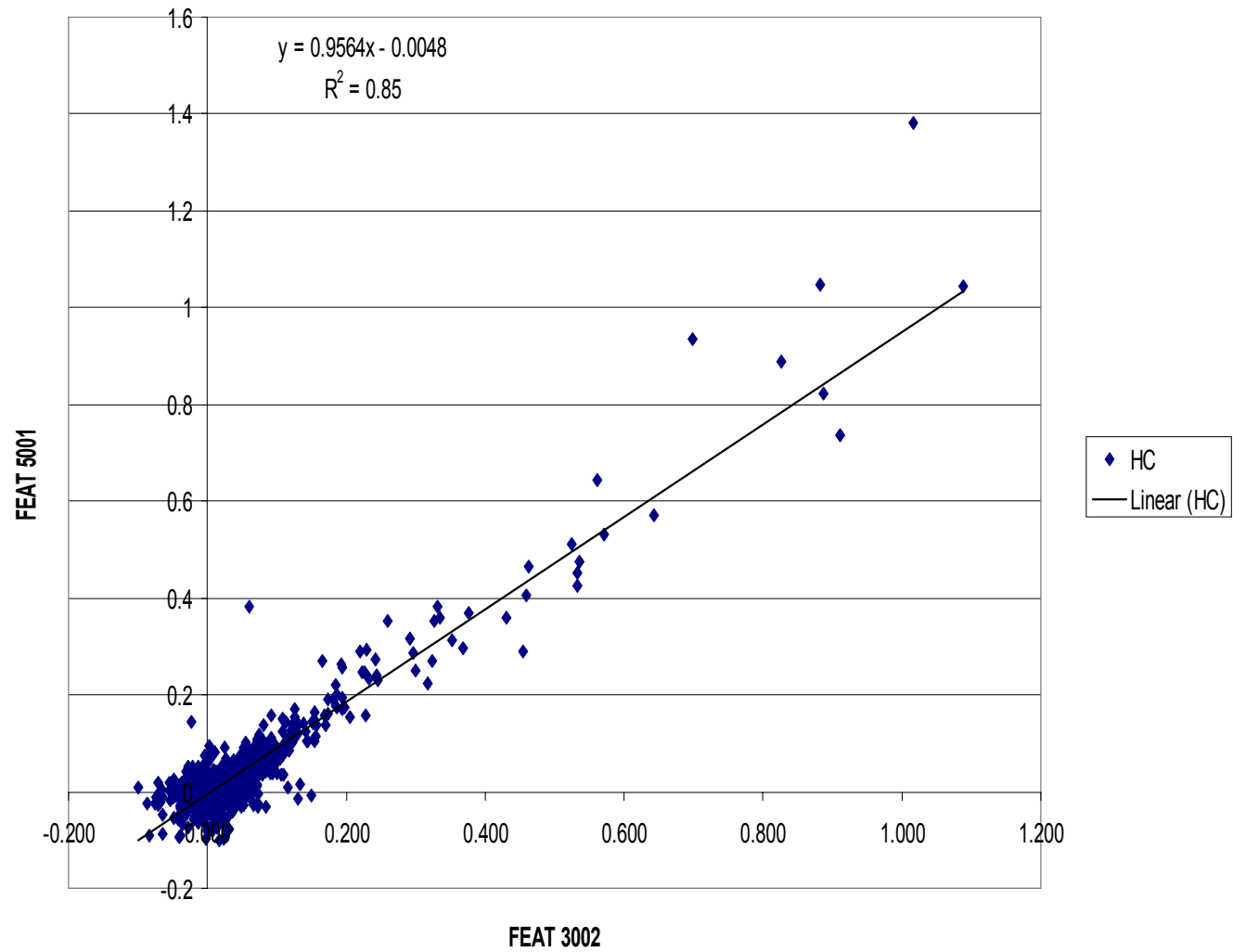

The New System Should:

Agree with the old

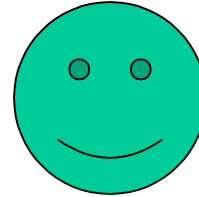

Self correct for CO₂ variation

Distinguish “Steamers” from high HC
Vehicles

SGM Parking Lot
February 2003
Self-Calibration Test

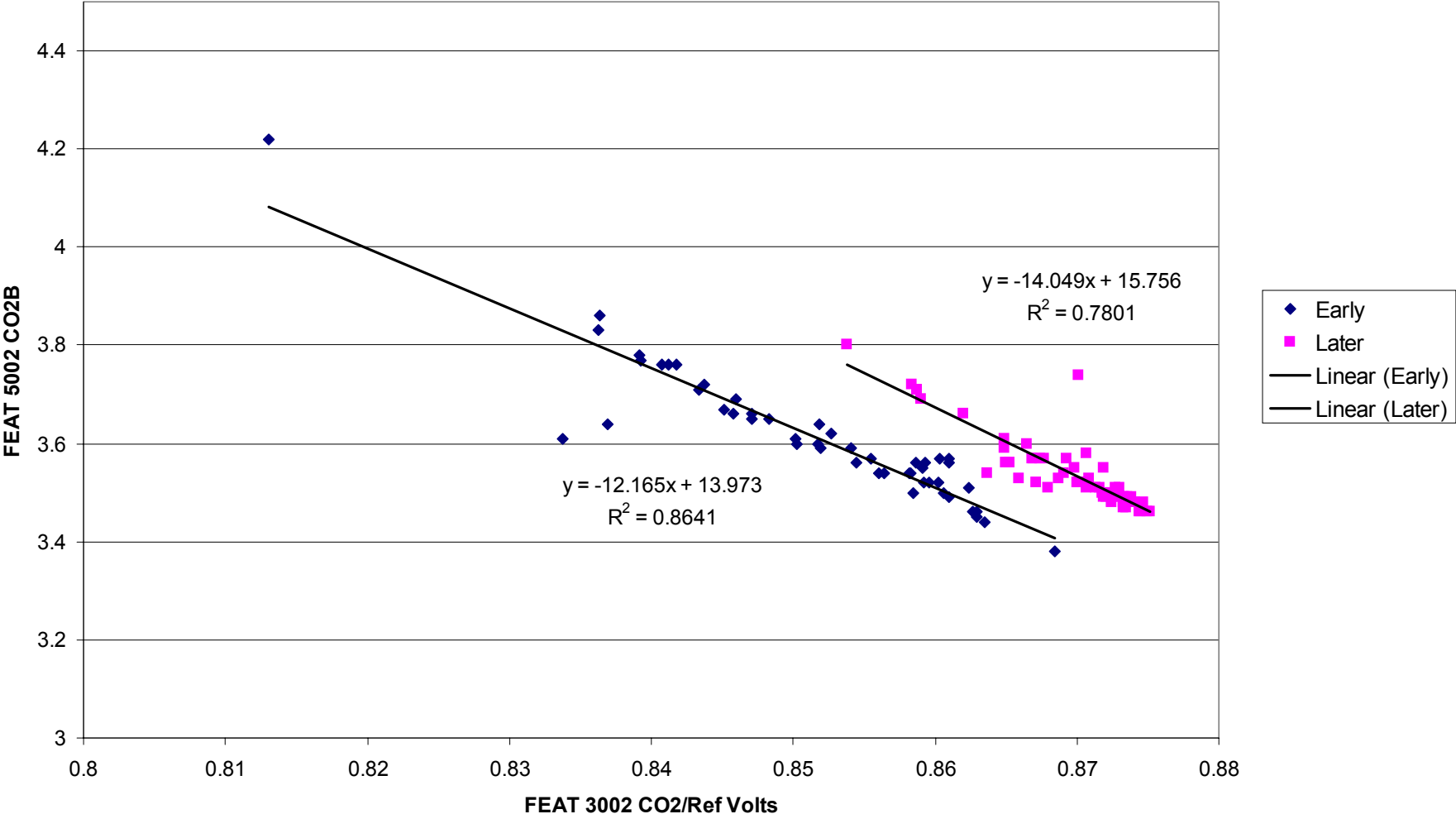

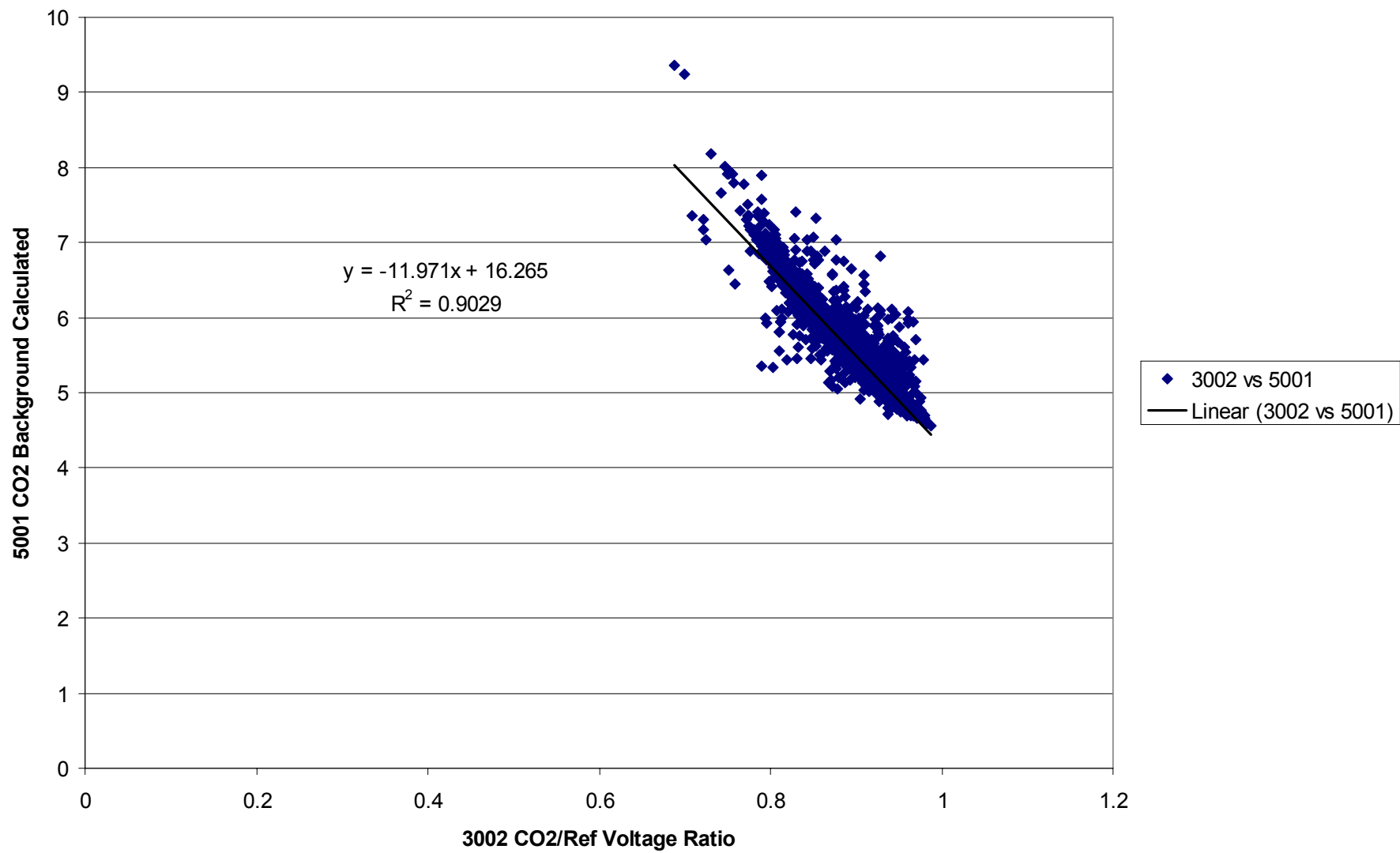

The New System Should:

Agree with the old

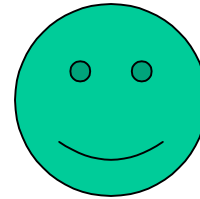

Self correct for CO₂ variation

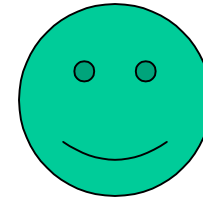

Distinguish “Steamers” from high HC
Vehicles

CHICAGO 1990

Eisenhower On Ramp before 9:30AM

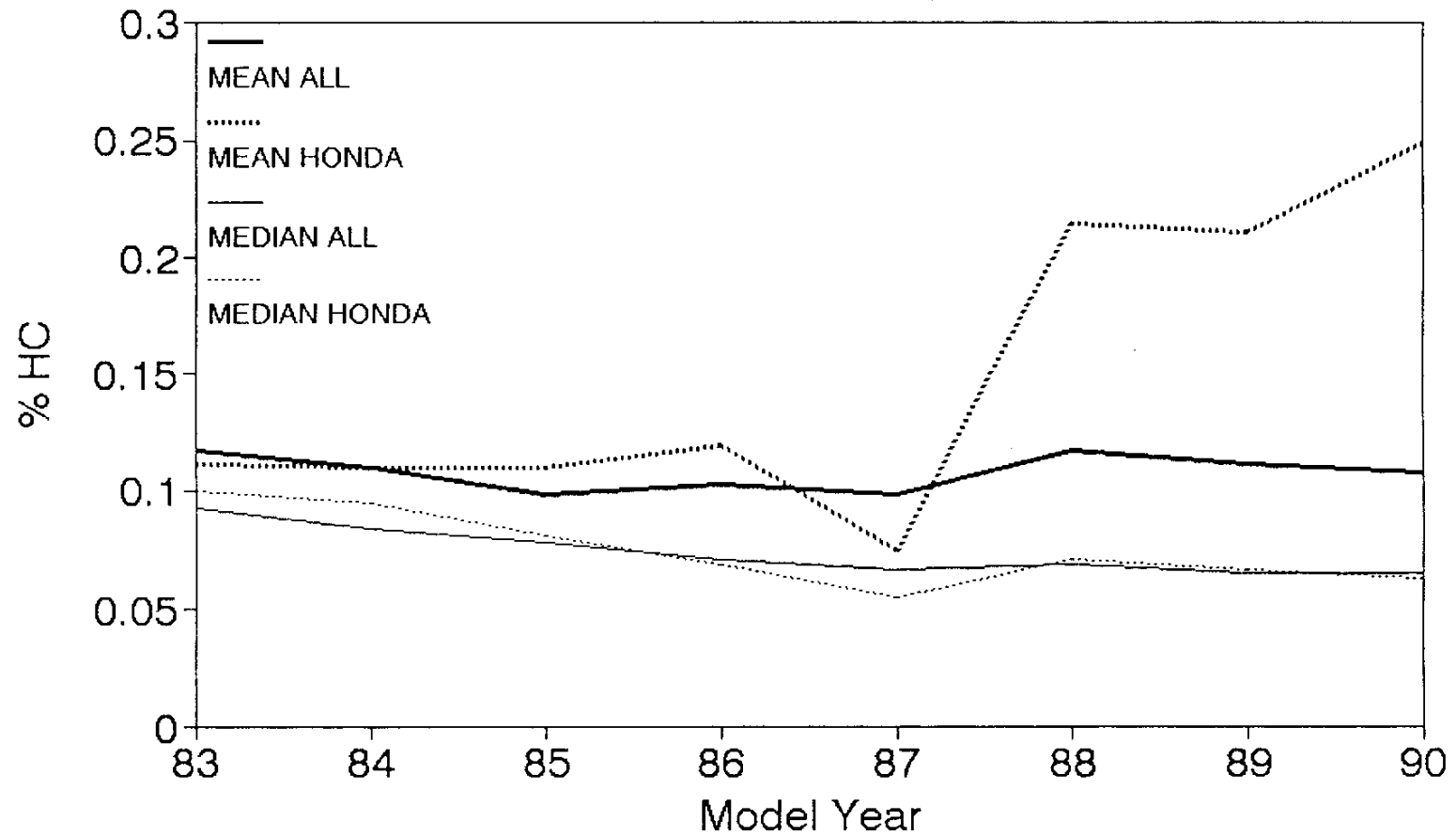

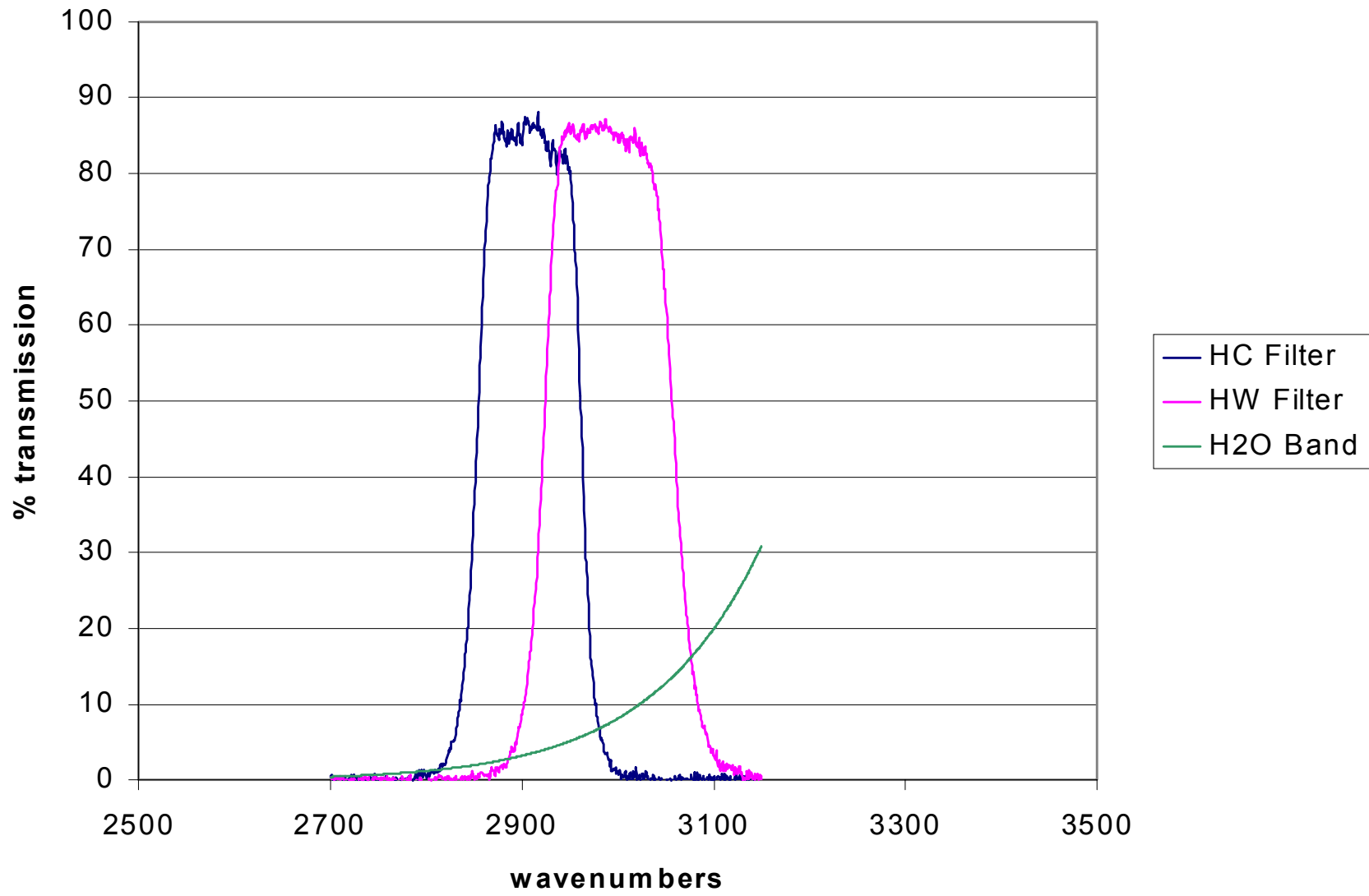

Steamers

HW vs. HC

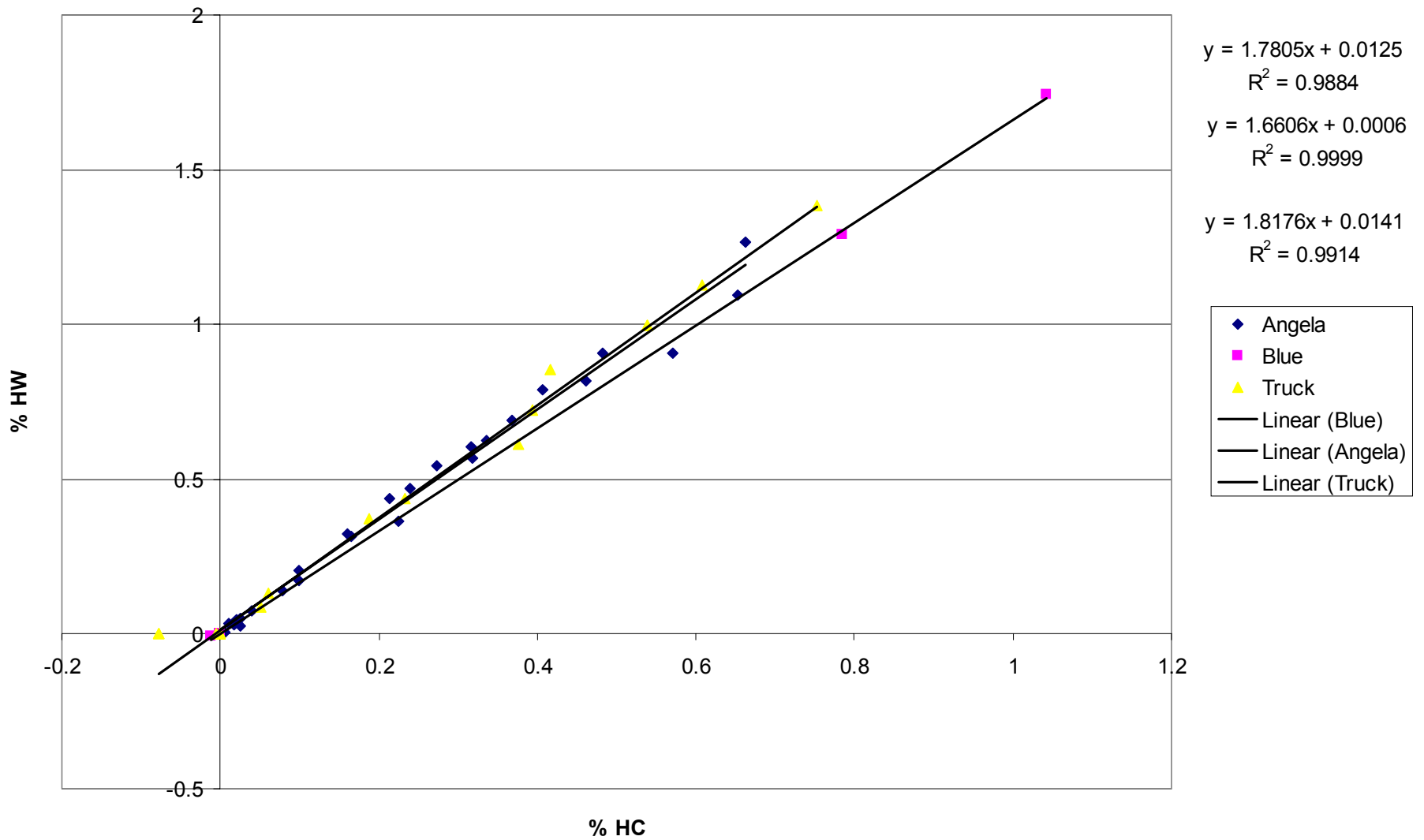

Some Steamers

HW vs. HC

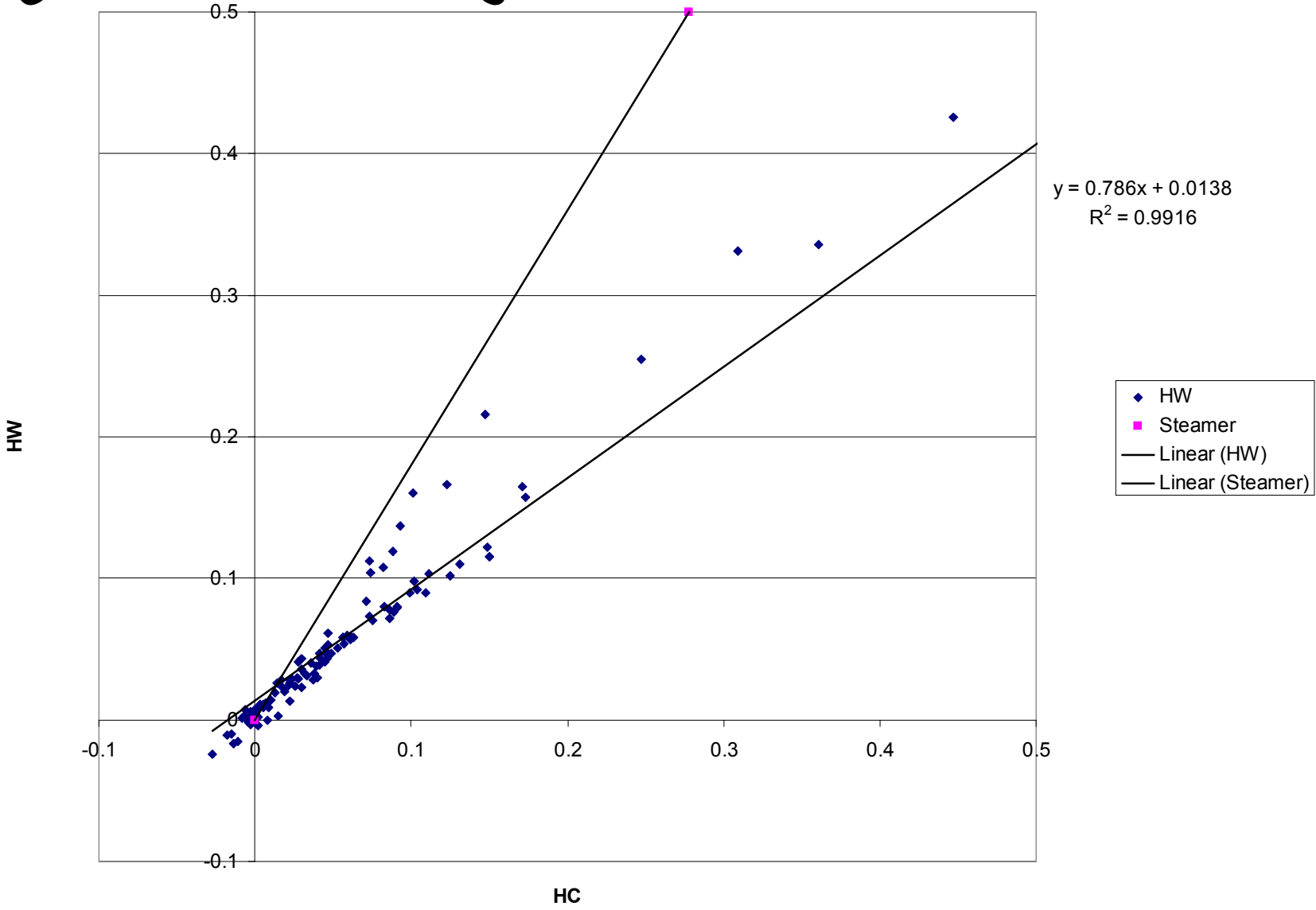

No Steamers

HW vs. HC Correlation 5001
7376 Measurements

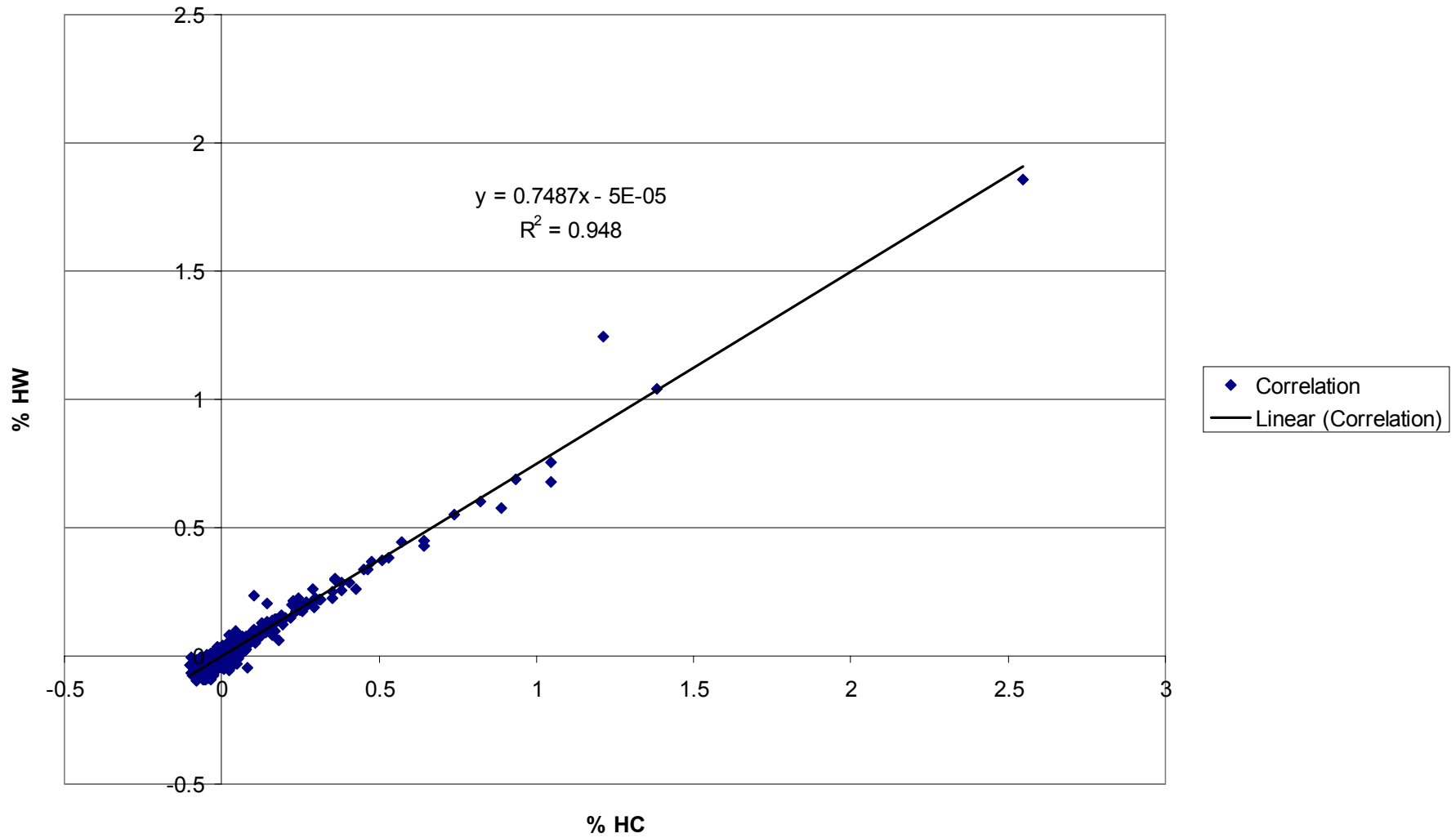

All readings > 1000 ppm Propane

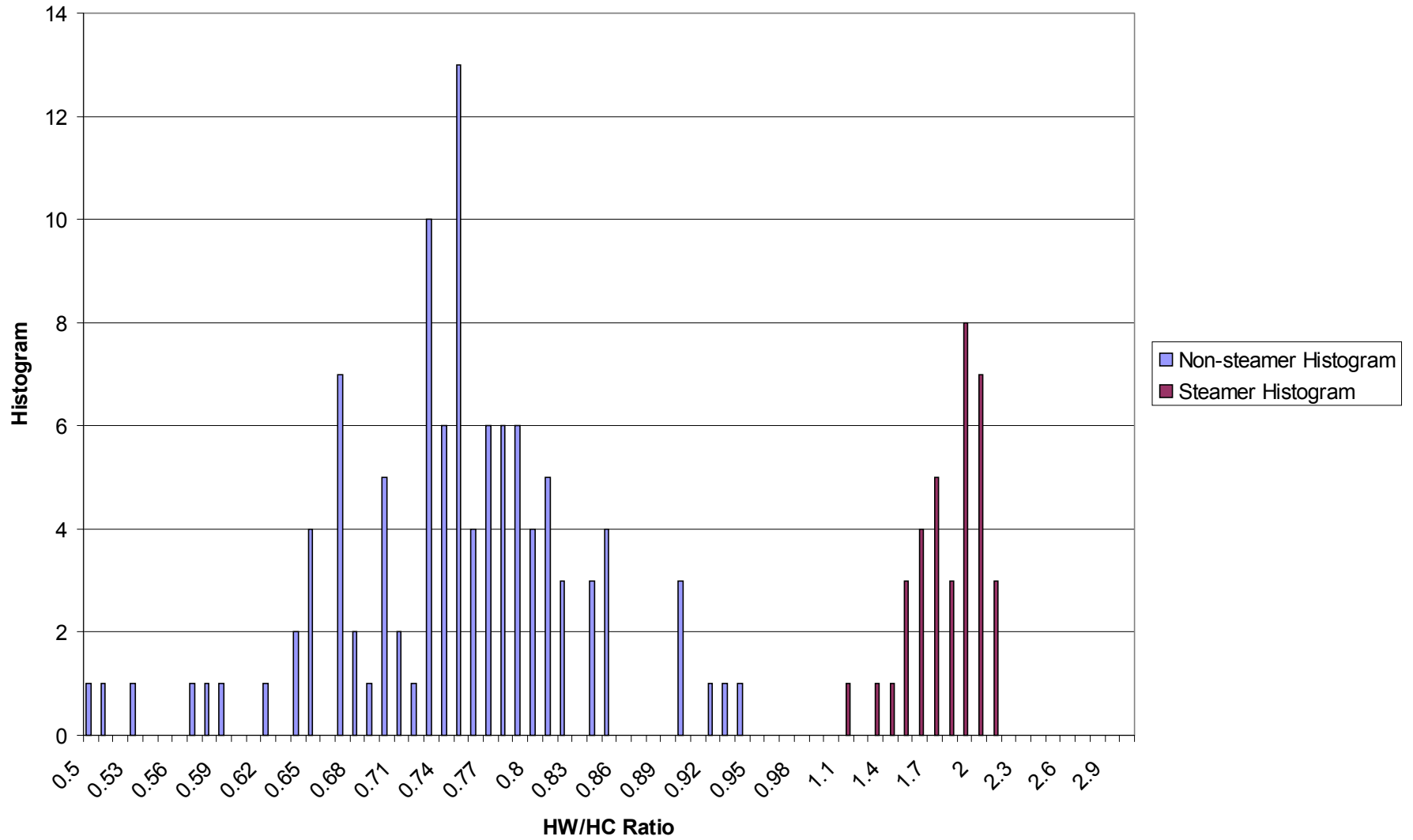

The New System Should:

Agree with the old

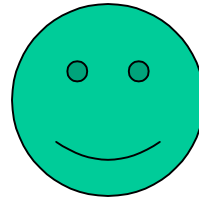

Self correct for CO₂ variation

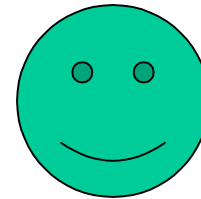

Distinguish “Steamers” from high HC
Vehicles

